

8

7

6

5

4

3

2

1

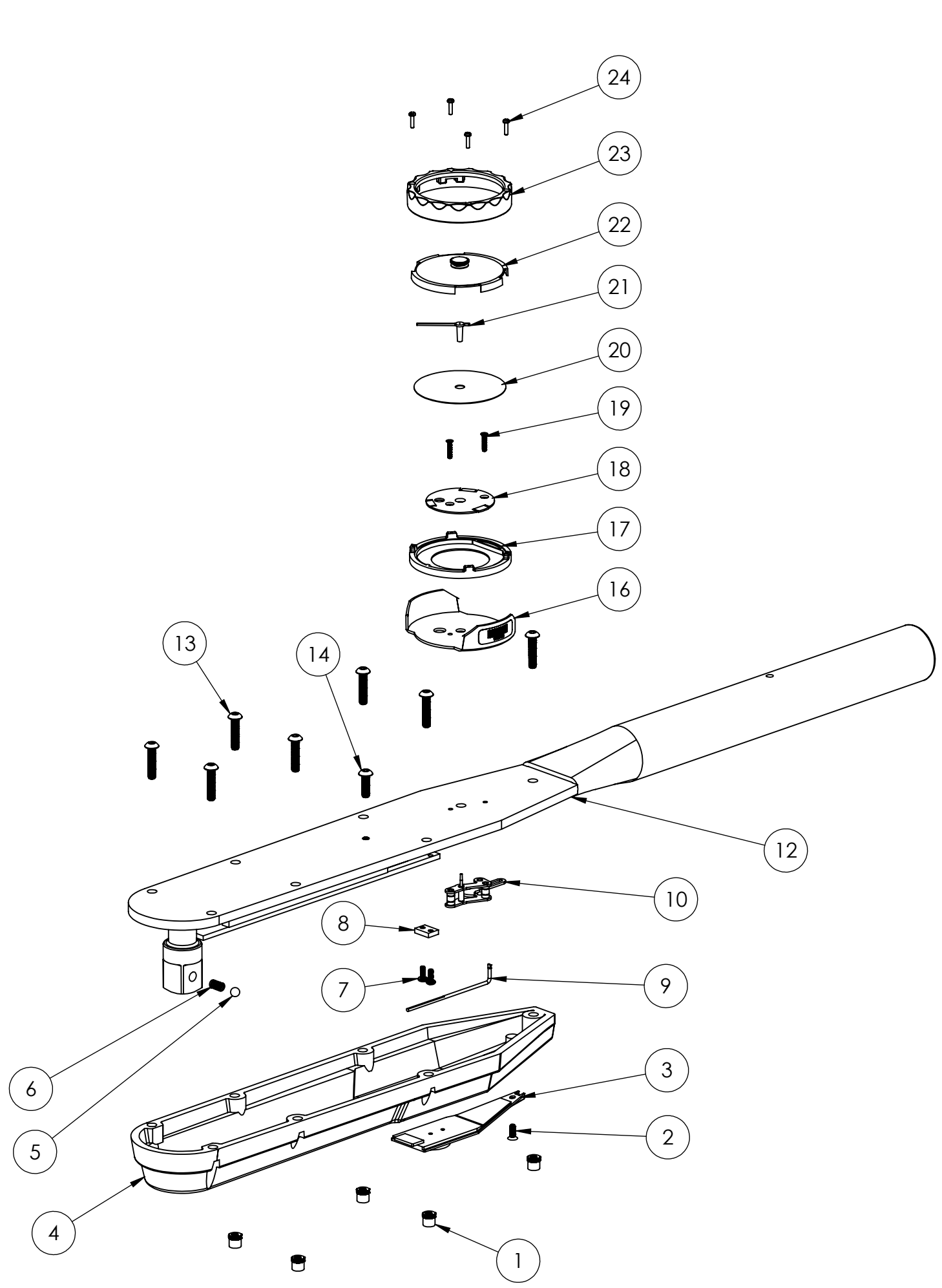

D4-350F
 350 FT-LB MECHANICAL DIAL
 TORQUE WRENCH

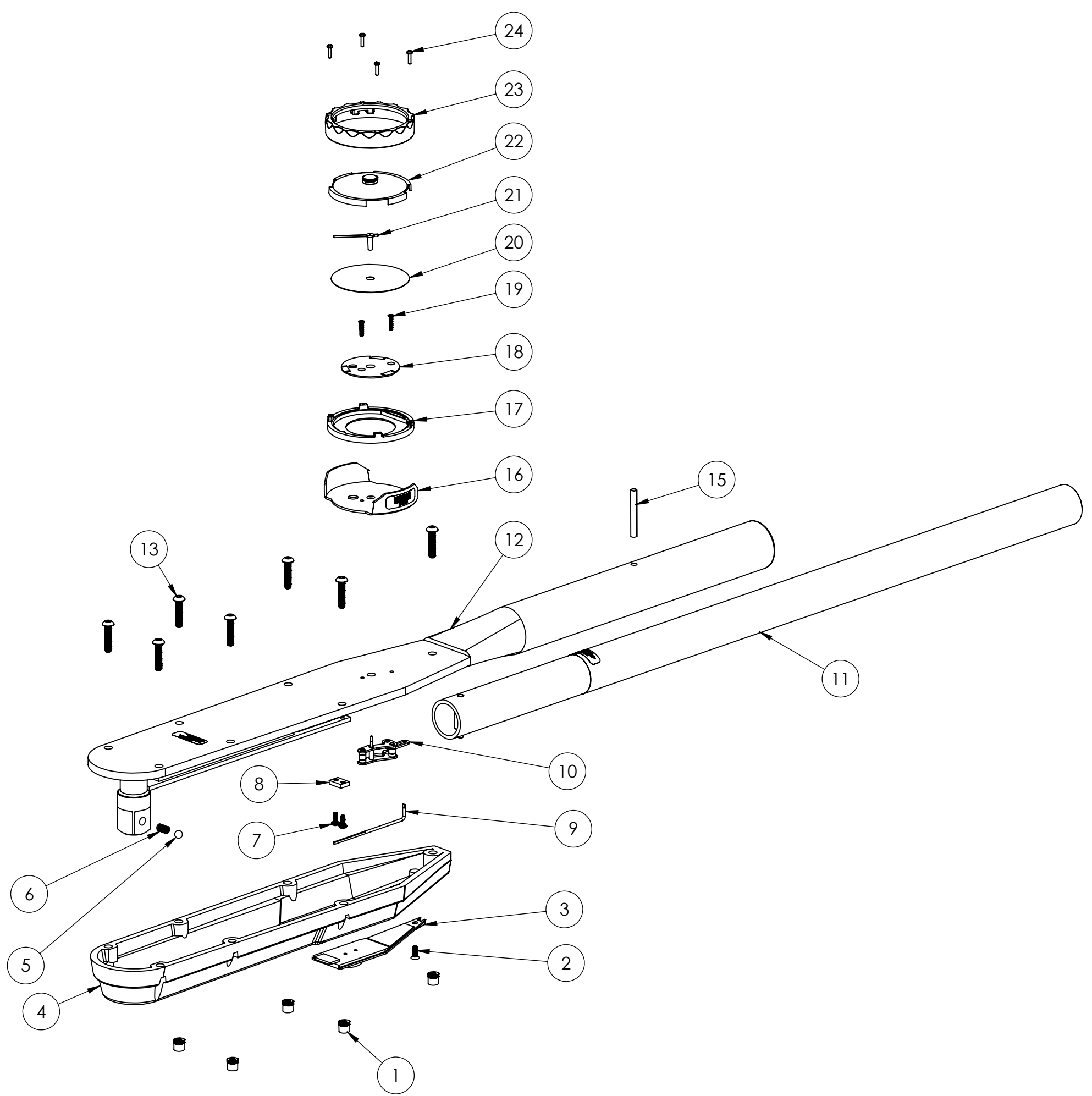

D4-600F
 600 FT-LB MECHANICAL DIAL
 TORQUE WRENCH

UNCONTROLLED COPY
 THE INFORMATION IN THIS DOCUMENT IS SUBJECT TO CHANGE WITHOUT NOTICE

JETCO <small>A Schwalbe Group Company Torque Tools LLC</small>	
TITLE D4 MECHANICAL DIAL TORQUE WRENCH SPARE PARTS DIAGRAM 350 & 600 FT-LB MODELS	
DWG NO. 35-0006	SHEET 1 OF 3
	SIZE C

UNLESS OTHERWISE SPECIFIED DIMENSIONS ARE IN INCHES

8

7

6

5

4

3

2

1

MECHANICAL DIAL TORQUE WRENCH		
PART NO.	D4-350F	D4-600F
TORQUE RANGE	DUAL SCALE 0 - 350 ft-lb 0 - 480 N-m	DUAL SCALE 0 - 600 ft-lb 0 - 800 N-m
DRIVE	3/4"	3/4"
GRADUATIONS	10 ft-lb 10 N-m	10 ft-lb 25 N-m

ITEM NO.	DESCRIPTION	QTY / ASSY		MECHANICAL DIAL TORQUE WRENCH ASSEMBLY NO.	
		D4-350F	D4-600F	D4-350F	D4-600F
1	INSERT	5		60-0057	
2	BATTERY COVER SCREW	1		60-0017	
3	BATTERY COVER	1		81-0103	
4	HOUSING	1		85-0001	
5	BALL	1		81-0106	
6	SPRING	1		81-0093	
7	SCREW	2		60-0044	
8	PUSH BAR CLAMP	1		81-0087	
9	PUSH BAR	1		81-0071	
10	JEWEL MOVEMENT	1		1730	
11	HANDLE EXT. ASSY	N/A	1	N/A	38-0006
12	TOP PLATE ASSY	1		38-0017	38-0018
13	TOP PLATE SCREW	4	7	60-0055	
14	SCREW	1	N/A	60-0020	N/A
15	PIN SPRING	N/A	1	N/A	60-0021
16	DIAL GUARD	1		81-0076	
17	FOLLOWER SHELL	1		81-1049	
18	FIXED SHELL	1		81-0073	
19	SCREW	2		60-0003	
20	BLANK SCALE	1		81-0077	
21	NEEDLE INDICATOR	1		81-0119-L	
22	MEMORY NEEDLE ASSY	1		81-1059	
23	DIAL BEZEL	1		81-1048	
24	BEZEL SCREW	4		60-0047	
25	LENS GUARD	1	N/A	85-0052	N/A
26	WASHER	1	N/A	81-1114	N/A
27	SCREW	3	N/A	60-0064	N/A

UNCONTROLLED COPY

THE INFORMATION IN THIS DOCUMENT IS SUBJECT TO CHANGE WITHOUT NOTICE

	
TITLE D4 MECHANICAL DIAL TORQUE WRENCH SPARE PARTS DIAGRAM 350 & 600 FT-LB MODELS	
DWG NO. 35-0006	SHEET 2 OF 3
	SIZE C

UNLESS OTHERWISE SPECIFIED DIMENSIONS ARE IN INCHES

NOTES:

- 1 LASER ETCH SERIAL NUMBER IN THE LOCATION SHOWN
- 2 APPLY SERIAL NUMBER/BAR CODE LABEL ON THE SIDE OF THE DIAL GUARD

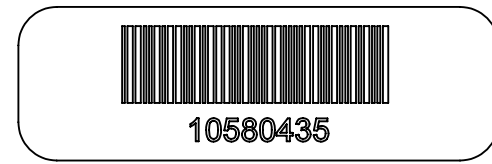

- 3 APPLY WARRANTY LABEL ON THE TOP PLATE AS SHOWN (D4-600F ONLY)



- 4 APPLY INJURY WARNING LABEL ON THE HANDLE AS SHOWN (D4-600F ONLY)



- 5 APPLY CALIBRATION LABEL AS SHOWN (D4-600F ONLY)

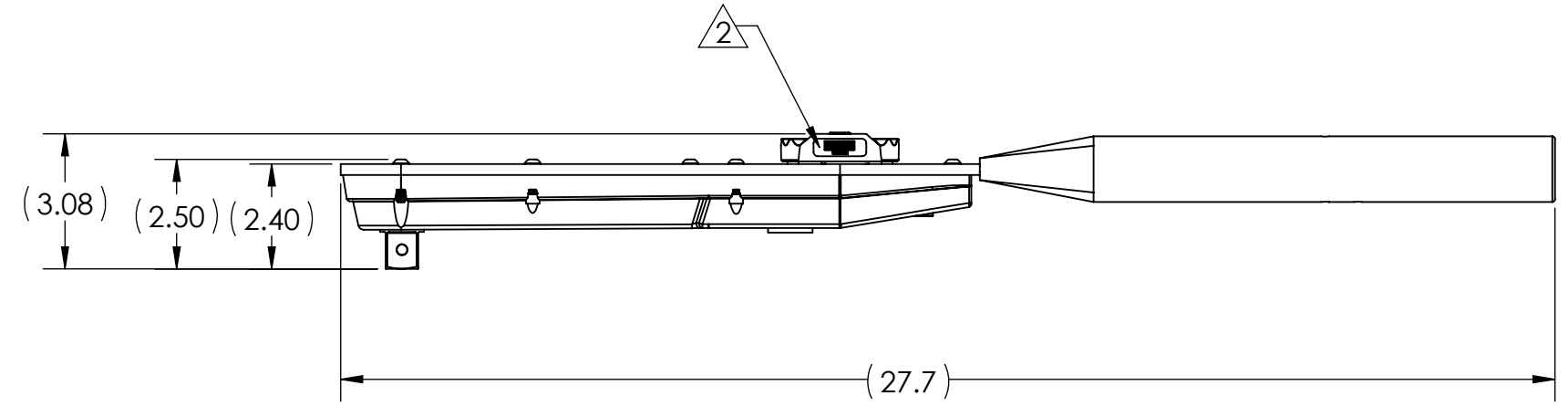
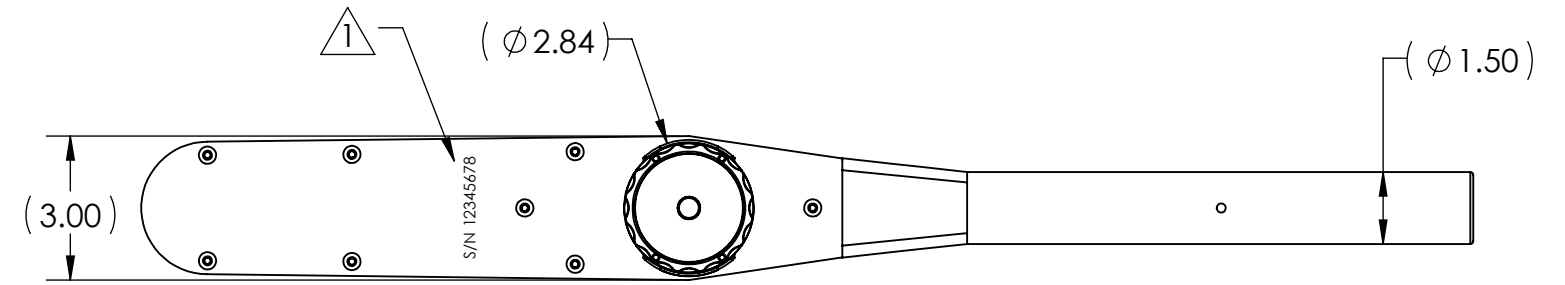

D4-350F

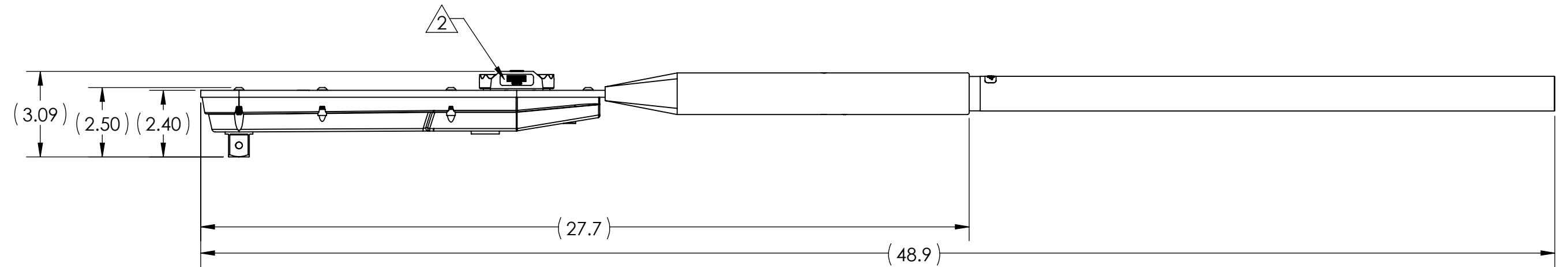
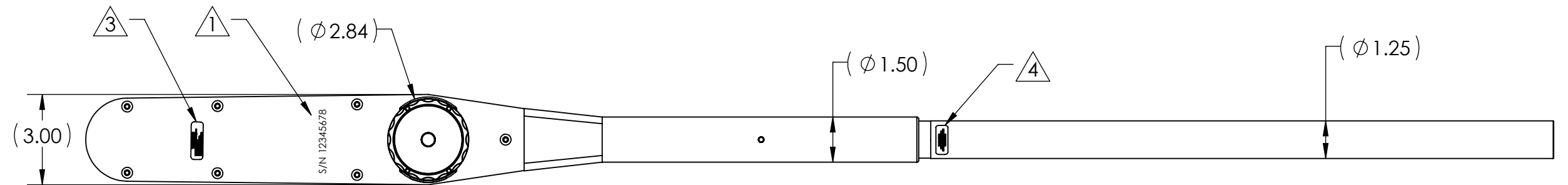

D4-600F

UNCONTROLLED COPY

THE INFORMATION IN THIS DOCUMENT IS SUBJECT TO CHANGE WITHOUT NOTICE



TITLE **D4 MECHANICAL DIAL TORQUE WRENCH SPARE PARTS DIAGRAM 350 & 600 FT-LB MODELS**

DWG NO. 35-0006	SHEET 3 OF 3
	SIZE C

UNLESS OTHERWISE SPECIFIED DIMENSIONS ARE IN INCHES