

| ITEM NO. | DESCRIPTION | QTY / ASSY | MECHANICAL DIAL TORQUE WRENCH ASSEMBLY NO. |
|----------|----------------------|------------|--|
| | | | D4-1000F |
| 1 | INSERT | 5 | 60-0057 |
| 2 | BATTERY COVER ASSY | 1 | 38-0055 |
| 3 | BATTERY | 2 | CR2032 |
| 4 | HOUSING | 1 | 85-0001-1 |
| 5 | POGO SLEEVE | 1 | 81-010 |
| 6 | DELRIN FLANGE | 1 | 85-0085 |
| 7 | POGO PROBE | 1 | 81-0109 |
| 8 | PUSH ROD | 1 | 81-0071 |
| 9 | SCREW | 2 | 60-0044 |
| 10 | PUSH BAR CLAMP | 1 | 81-0087 |
| 11 | JEWEL MOVEMENT | 1 | 1730 |
| 12 | ELECTRICAL STANDOFF | 1 | 81-0107 |
| 13 | PCBA | 1 | 70-100 |
| 14 | NUT | 1 | 60-0012 |
| 15 | STEEL BALL | 1 | 81-0106 |
| 16 | SPRING | 1 | 81-0093 |
| 17 | HANDLE EXTENSION | 1 | 38-0007 |
| 18 | TOP PLATE ASSY | 1 | 38-0021 |
| 19 | SCREW | 1 | 60-0013 |
| 20 | GROMMET | 1 | 81-0031 |
| 21 | SCREW | 7 | 60-0056 |
| 22 | SPRING PIN | 1 | 60-0022 |
| 23 | DIAL GUARD | 1 | 81-0076 |
| 24 | FIXED SHELL | 1 | 81-0073 |
| 25 | FOLLOWER SHELL | 1 | 81-1049 |
| 26 | SCREW | 2 | 60-0003 |
| 27 | BLANK SCALE | 1 | 81-0077 |
| 28 | SPRING | 1 | 81-0113 |
| 29 | COPPER RING CONTACT | 1 | 85-0087 |
| 30 | BRASS FLANGE CONTACT | 1 | 85-0086 |
| 31 | POINTER NEEDLE | 1 | 81-0119-1 |
| 32 | DIAL MEMORY ASSY | 1 | 38-0059 |
| 33 | DIAL BEZEL | 1 | 81-1048 |
| 34 | PLASTITE SCREW | 4 | 60-0047 |

| MECHANICAL DIAL TORQUE WRENCH | |
|-------------------------------|------------------------------|
| PART NO. | D4-1000F |
| TORQUE RANGE | 0-1000 ft-lb (0-1400 N-m) |
| DRIVE | 1" |
| GRADUATIONS | 20 ft-lb (25 N-m) |

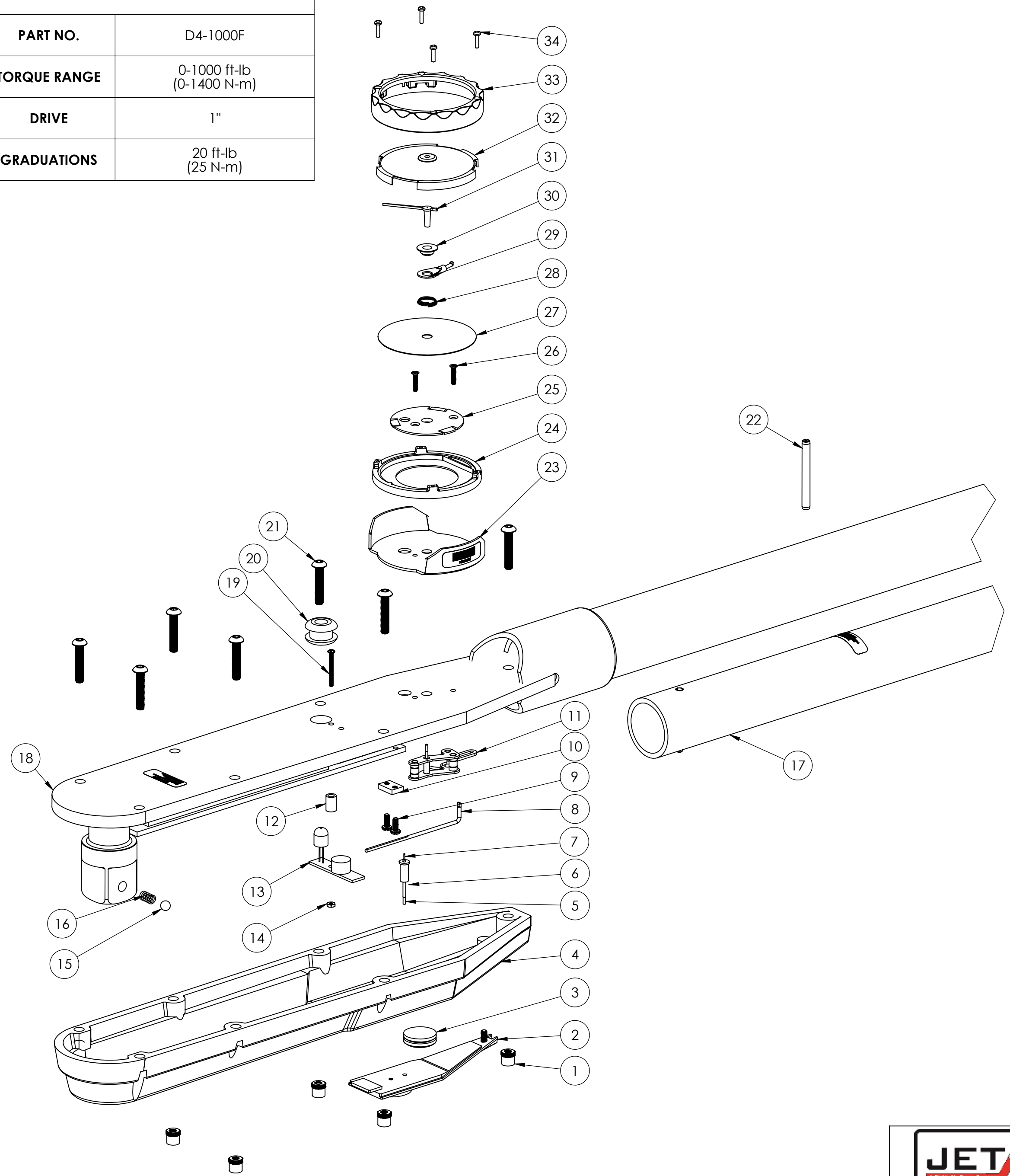

UNCONTROLLED COPY

THE INFORMATION IN THIS DOCUMENT IS SUBJECT TO CHANGE WITHOUT NOTICE



TITLE
D4 MECHANICAL DIAL TORQUE WRENCH SPARE PARTS DIAGRAM

| | | | |
|---------|---------|-------|--------|
| DWG NO. | 35-0007 | SHEET | 1 OF 2 |
| SIZE | C | | |

UNLESS OTHERWISE SPECIFIED DIMENSIONS ARE IN INCHES

NOTES:

- 1 LASER ETCH SERIAL NUMBER IN THE LOCATION SHOWN
- 2 APPLY SERIAL NUMBER/BAR CODE IN THE LOCATION SHOWN



- 3 APPLY WARRANTY LABEL ON THE TOP PLATE AS SHOWN



- 4 APPLY INJURY WARNING LABEL ON THE HANDLE AS SHOWN AS SHOWN



- 5 APPLY BATTERY LABEL AS SHOWN

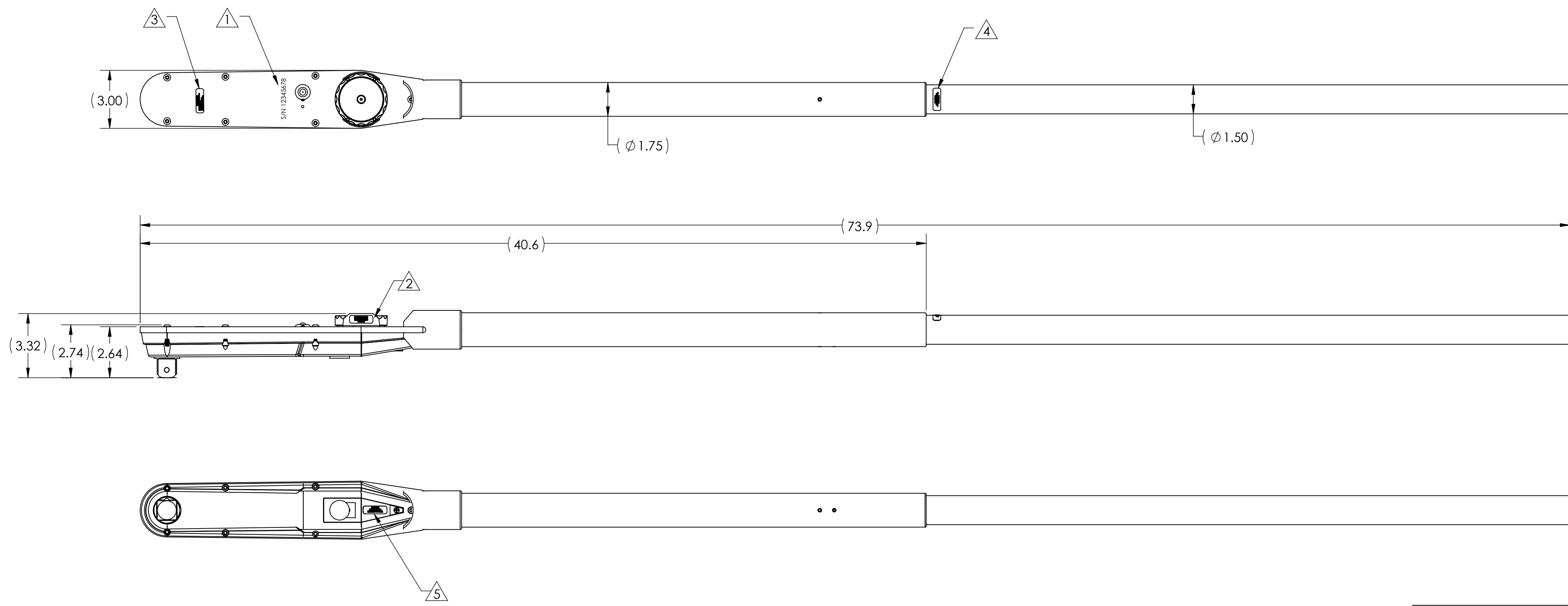
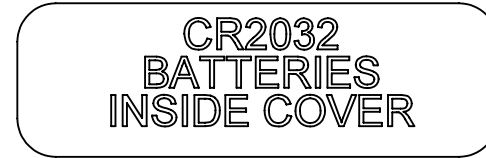

UNCONTROLLED COPY
THE INFORMATION IN THIS DOCUMENT IS SUBJECT TO CHANGE WITHOUT NOTICE

JETCO
A Schmalz Group Company Torque Tools LLC

TITLE
D4 MECHANICAL DIAL TORQUE WRENCH SPARE PARTS DIAGRAM

DWG NO. **35-0007**

SHEET **2 OF 2**

SIZE **C**

UNLESS OTHERWISE SPECIFIED DIMENSIONS ARE IN INCHES