

ELECTRONIC TORQUE WRENCH					
JETCO MODEL NO.	ED-50I	ED-75I	ED-100I	ED-250I	ED-50F
TORQUE RANGE	5-50 in-lb (.56 - 5.65 N-m) (.42 - 4.2 ft-lb)	7.5 - 75 in-lb (.85 - 8.5 N-m) (.625 - 6.25 ft-lb)	10 - 100 in-lb (1.1 - 11 N-m) (.83 - 8.3 ft-lb)	25 - 250 in-lb (2.8 - 28.8 N-m) (2.1 - 21 ft-lb)	5 - 50 ft-lb (60 - 600 in-lb) (6.8 - 67.8 N-m)
DRIVE SIZE	1/4"	1/4"	1/4"	3/8"	3/8"

ITEM NO.	DESCRIPTION	QTY / ASSY	BILL OF MATERIALS				
			ED-50I	ED-75I	ED-100I	ED-250I	ED-50F
1	HOUSING	1			38-0001		
2	PLUG	1			81-0102		
3	CIRCUIT BOARD	1			38-0098		
4	AAA BATT. ASSY.	1			38-0120		
5	SCREW	2			60-0025		
6	SNAP-IN PLUG	1			81-0033		
7	DRIVE	1	38-0033-1E	38-0033	38-0033-1	38-0019	38-0036
8	SPRING PIN	1			60-0034		
9	ADHESIVE TAPE	1			60-0097		
10	NUT	2			60-0024		
11	TOP PLATE ASSY	1			38-0023		
12	SCREW	5			60-0004		
13	SCREW	1			60-0010		
14	DIAL GUARD	1			81-0076-1		
15	FIXED SHELL	1			81-0073		
16	SCREW	2			60-0065		
17	PCB BOARD	1			70-300		
18	KEYPAD ASSY	1			38-0083		
19	PLASTITE SCREW	4			60-0047		

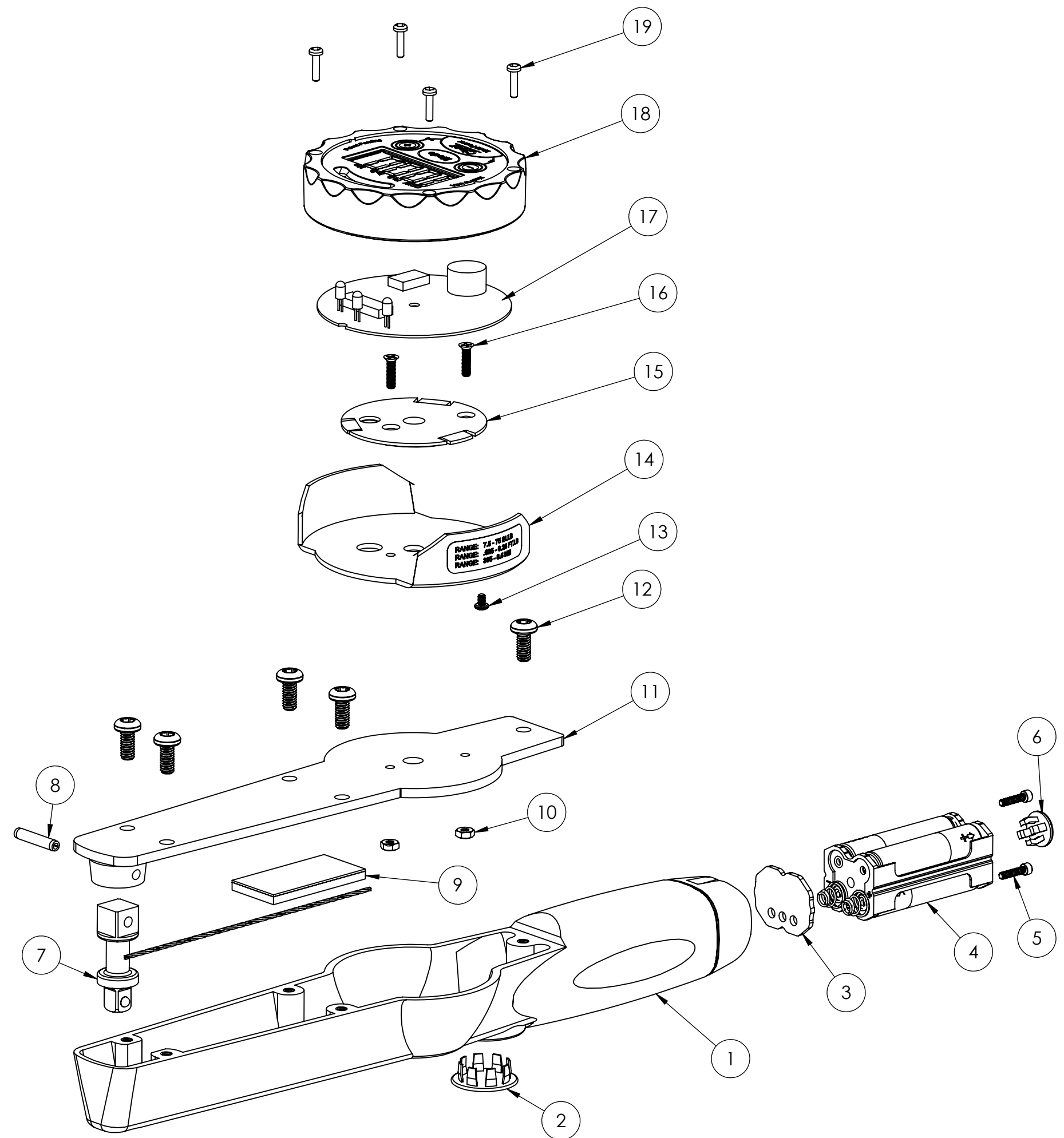

UNCONTROLLED COPY

THE INFORMATION IN THIS DOCUMENT IS SUBJECT TO CHANGE WITHOUT NOTICE

JETCO <small>A Schwalbe Group Company Torque Tools LLC</small>	
TITLE D1 ELECTRONIC TORQUE WRENCH SPARE PARTS DIAGRAM WRENCH REVISION B	
DWG NO. 35-0009	SHEET 1 OF 2
	SIZE C

UNLESS OTHERWISE SPECIFIED DIMENSIONS ARE IN INCHES

NOTES:

1 LASER ETCH LOGO, MODEL NUMBER, WRENCH REVISION, AND SERIAL NUMBER IN THE LOCATION SHOWN

2 APPLY LABEL ON LEFT SIDE OF THE DIAL GUARD AS SHOWN INDICATING THE TORQUE RANGE IN IN-LB, FT-LB, AND N-M. EXAMPLE OF LABEL FOR ED-75I MODEL:

RANGE: 7.5 - 75 IN.LB
 RANGE: .625 - 6.25 FT.LB
 RANGE: .85 - 8.5 NM

3 APPLY SERIAL NUMBER AND BAR CODE LABEL ON THE RIGHT SIDE OF THE DIAL GUARD AS SHOWN

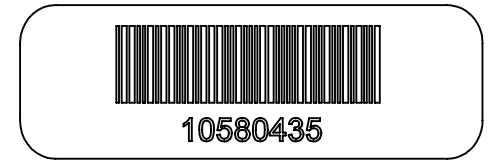

4 APPLY BATTERY LABEL ON THE BOTTOM OF THE HOUSING AS SHOWN

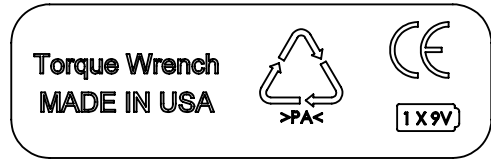

5 FOR REFERENCE:



D1 ELECTRONIC TORQUE WRENCH



KEYPAD DETAIL

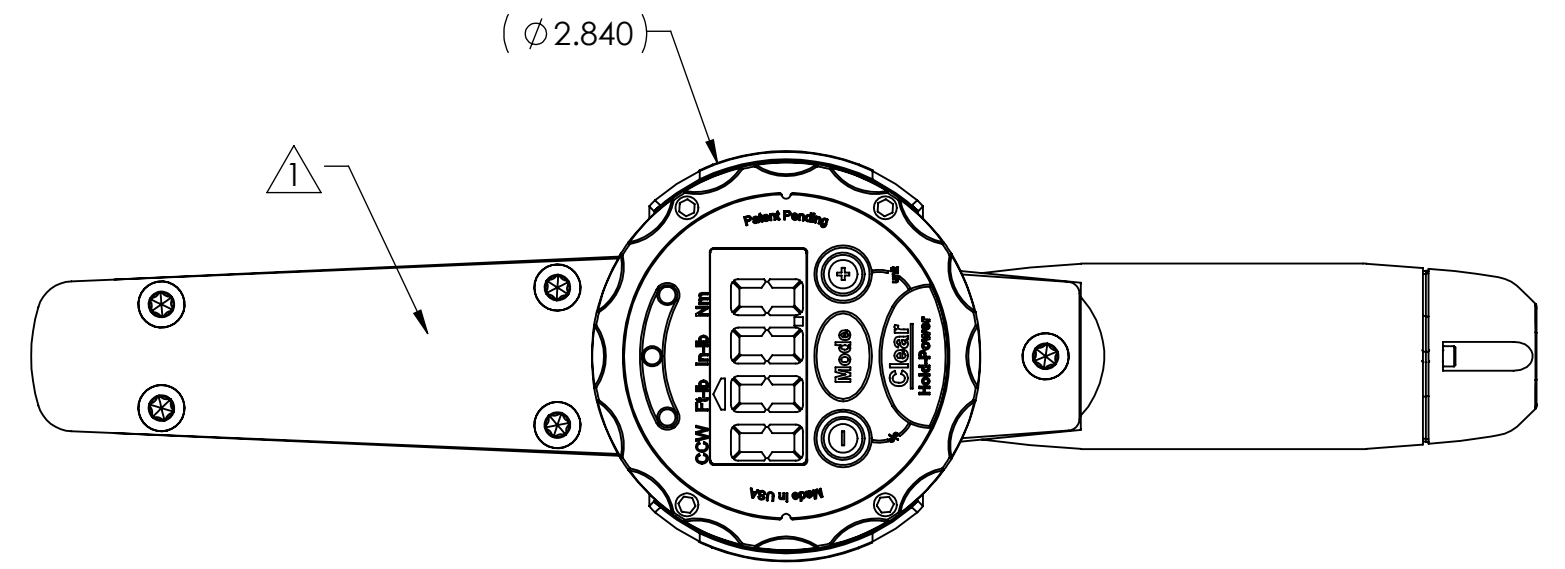

TOP VIEW

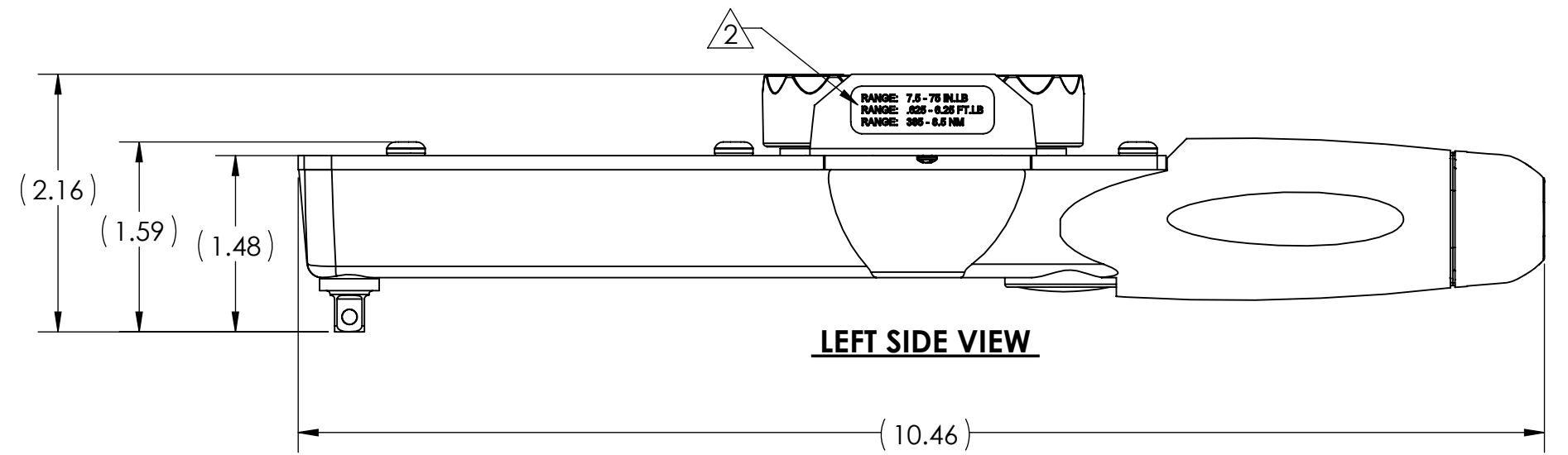

LEFT SIDE VIEW

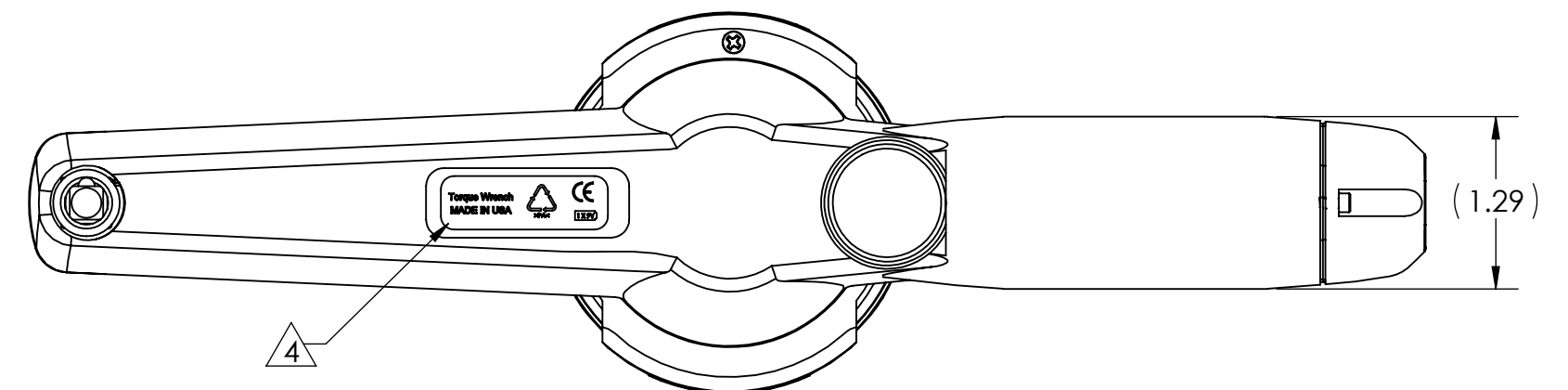

BOTTOM VIEW

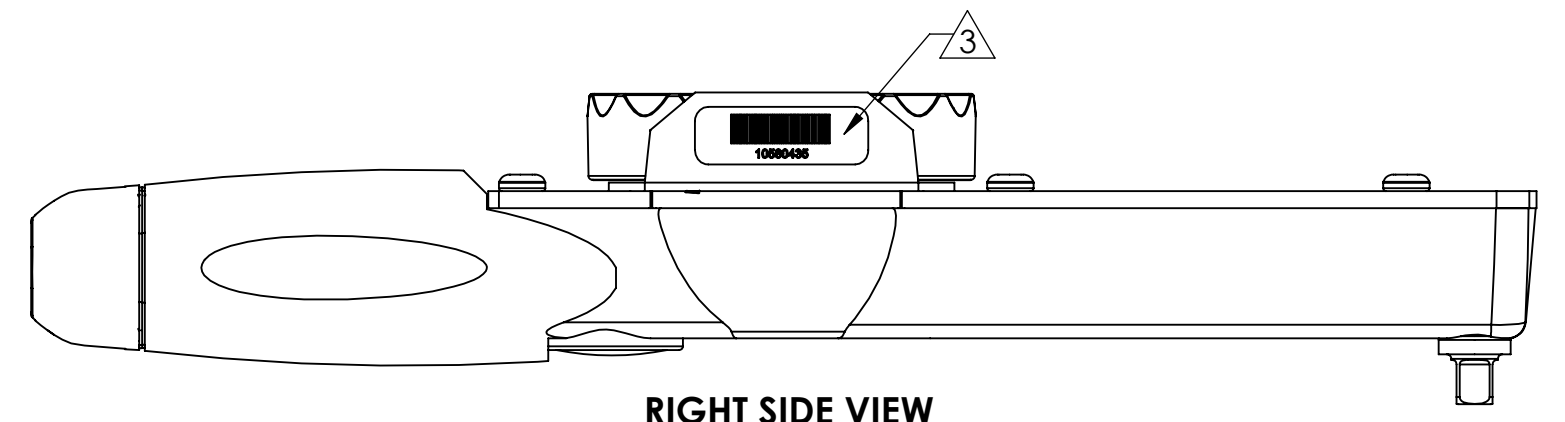

RIGHT SIDE VIEW

UNCONTROLLED COPY

THE INFORMATION IN THIS DOCUMENT IS SUBJECT TO CHANGE WITHOUT NOTICE



TITLE D1 ELECTRONIC TORQUE WRENCH SPARE PARTS DIAGRAM WRENCH REVISION B

DWG NO. 35-0009 SHEET 2 OF 2 SIZE C

UNLESS OTHERWISE SPECIFIED DIMENSIONS ARE IN INCHES